



Advanced Light Meter

840022

Instruction Manual

SPER
SCIENTIFIC LTD.



sale@ponpe.com

www.ponpe.com





TABLE OF CONTENTS

1. INTRODUCTION 2

2. PANEL DESCRIPTION..... 3

3. OPERATING INSTRUCTIONS

3-A. General Measurement..... 4

3-B. Hold 4

3-C. Peak Hold 4

3-D. Record Maximum / Minimum 4-5

3-E. Notes and Precautions 5

4. ZERO ADJUSTMENT AND CALIBRATION 5

5. BATTERY REPLACEMENT 5

6. RS232 SERIAL INTERFACE..... 5-6

7. SPECIFICATIONS 6-7

8. WARRANTY..... 8

1. INTRODUCTION

Monitor light levels anywhere with fast, stable and accurate response. Results are easily read on the extra large LCD with bar graph. Measures Foot Candles or Lux and offers high resolution, 5 ranges, selectable light source types (Tungsten, Fluorescent, Sodium or Mercury), max-min, peak, hold, RS232 output, zero adjustment, a tripod back, automatic power off, low battery and out of range indicators. The sensor is cosine and color corrected and hermetically sealed to ensure long term stability.

Comes ready to use with a 9V battery, instructions, carrying case, and a detachable sensor with cover for easier replacement or repair.



2. PANEL DESCRIPTION

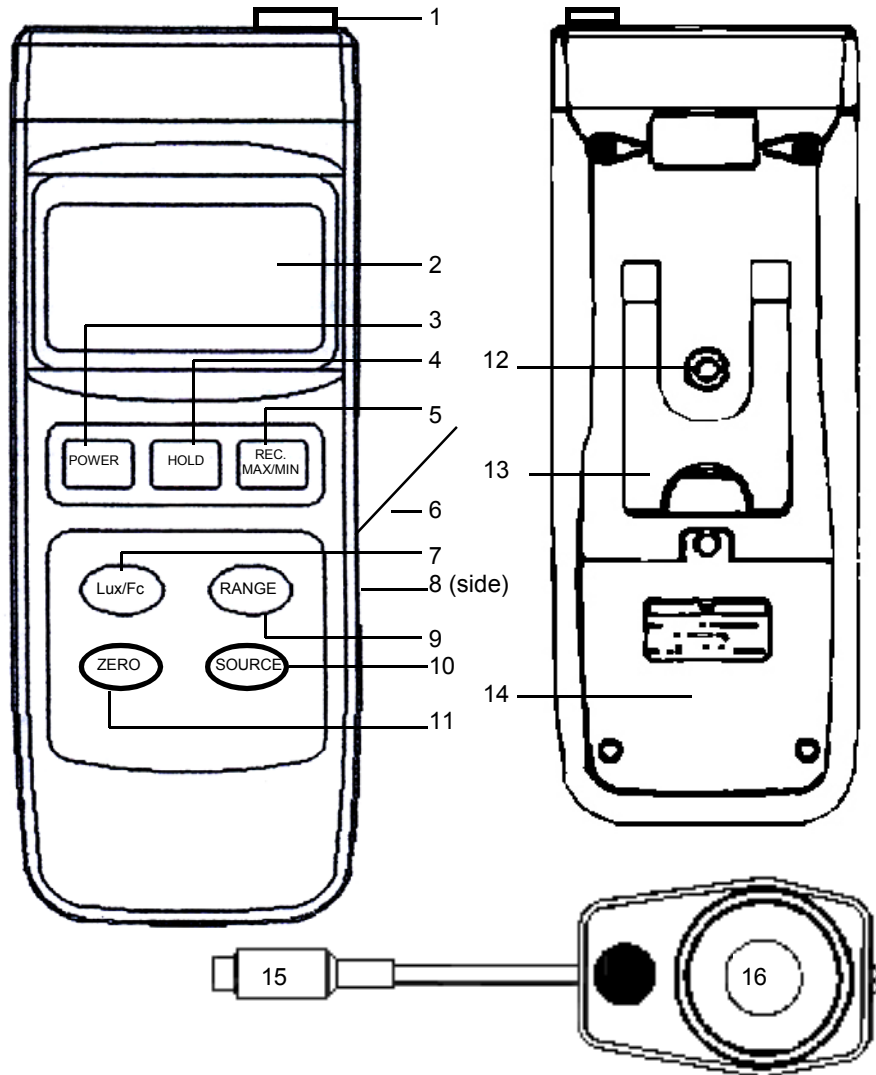

1. Sensor Input	2. Display	3. Power Button	4. Hold Button
5. REC. MAX/MIN Button	6. RS232 Cover (lifts)	7. Lux/FC Button	8. RS-232 Output (see 6)
9. Range Button	10. Source Button	11. Zero Button	12. Tripod Screw
13. Stand	14. Battery Cover	15. Sensor Plug	16. Photo Sensor

3. OPERATING INSTRUCTIONS

3-A. General Measurement

- Insert the **SENSOR** (15) plug into the **SENSOR INPUT** (1) and turn the meter on by pressing the **POWER** (3) button.
- Remove the lens cap from the **PHOTO SENSOR** (16) .
- Select the desired unit of measure by pressing the **LUX/FC** (7) button.
- Select the lighting type by pressing the **SOURCE** (10) button. The display shows "Hg" for Mercury, "Na" for Sodium, and "FL" for Fluorescent Lamp. For Tungsten and unknown sources use the standard mode - no indicator appears on the screen.
- Select the maximum range by pressing the **RANGE** (9) button. If the out of range indicator "- - -" appears, select another range or discontinue use. For the highest accuracy, select the range that offers the highest resolution (most number of digits after the decimal point).
- Point the **PHOTO SENSOR** (16) toward the source and read the results on the display.
- The instrument has an automatic shut off function in order to prolong battery life. After approximately 10 minutes without activity (no buttons pushed), the meter will automatically shut off. To disable this feature, press the **REC MAX/MIN** (5) button.
- Press the **POWER** (3) button to manually turn the meter off.

3-B. Hold

- During measurement, press **HOLD** (4) to freeze the measured value.
- "HOLD" and the value are displayed.
- Press the **HOLD** (4) button again to exit.

3-C. Peak Hold

- During measurement, press the **HOLD** (4) button for 2 to 3 seconds.
- "Peak HOLD" and the peak value are displayed and updated if exceeded.
- To erase the peak value, press the **HOLD** (4) button once (the display will flash).
- To exit this function, press the **HOLD** (4) button for at least 2 seconds.

3-D. Record Maximum / Minimum

- Press the **REC MAX/MIN** (5) button once to enter the recording mode. "REC" and the recorded values are displayed and continuously updated.
- Press the **REC MAX/MIN** (5) button as needed to view the recorded Max and Min values. "REC Max" and the maximum recorded value or "REC Min" and the minimum recorded value are displayed.
- Note: The Max/Min values are frozen and not updated until the meter returns to recording mode.

- To return to recording mode, press the **HOLD** (4) button. "REC" is displayed without "Max" or "Min".
- To erase the recorded Max/Min values and exit the recording mode, press the **REC MAX/MIN** (5) button for at least 2 seconds.

3-E. Notes and Precautions

- Avoid range overload.
- When using PEAK HOLD (3-C) or REC MAX/MIN (3-D) your measurements must be within the selected range, if not, the out of range indicator "- - -" will be displayed.
- Cover the **PHOTO SENSOR** (16) with the sensor cap when the meter is not in use.
- Fluctuations in the reading are often due to shadows or a weak battery. Also, ambient temperatures and drafts may affect the reading.
- Do not store in areas of high temperature and/or humidity.
- Remove the battery for long-term storage.
- Do not adjust the calibration trimmer beneath the **RS232 Cover** (6).

4. ZERO ADJUSTMENT AND CALIBRATION

- With the sensor cover securely in place and the meter turned on, use the **RANGE** (9) button to select the 40.00 Lux range (digits appear).
- Press the **ZERO** (11) button and the "0.00 LUX" should be displayed.
- To maintain accuracy, annual laboratory calibration is recommended and available from Sper Scientific.

5. BATTERY REPLACEMENT



- Replace the battery when the low battery icon is displayed.
- In-spec measurements may be made for several hours after the low battery indicator appears.
- Remove the **BATTERY COVER** (14) screw and slide the cover off.
- Replace the battery with a fresh 9V battery (alkaline or heavy duty).

6. RS232 PC SERIAL INTERFACE

Use a small screwdriver to gently lift the **RS232 COVER** (6) up to expose the **RS232 OUTPUT** (8) 3.5 mm terminal. The signal output is a 16-digit data stream that can be adapted to user-defined applications. A RS232 lead with the following connection is required to link the instrument with the PC serial interface.

Meter (3.5 mm jack plug)	PC (9W 'D' Connector)	
Center Pin	Pin 4	Pin 2 } 2.2 K
Ground/shield	Pin 2	Pin 5 } resistor

The 16 digits data stream will be displayed in the following format:	
D15 D14 D13 D12 D11 D10 D9 D8 D7 D6 D5 D4 D3 D2 D1 D0	
Each digit indicates the following status:	
D0	End Word
D1 & D8	Display reading, D1 = LSD, D8 = MSD E.g: If the display reading is 1234, then D8 to D1 is: 00001234
D9	Decimal Point (DP), position from right to the left 0 = No DP, 1 = 1 DP, 2 = 2 DP, 3 = 3 DP
D10	0 = Positive 1 = Negative
D11 & D12	Annunciator for Display Lux = 15, Ft-cd = 16
D13	The upper display data = 1, The lower display data = 2
D14	4
D15	Start Word
RS232: 9600, N, 8, 1	

SPECIFICATIONS

Display	Large 2" x 1.5" (52 mm x 38 mm), 5 digit display with bar graph indicator.
Out of Range Indicator	"- - -" appears at the top of the display for over-range, or at the bottom of the display for under-range.
Operating Environment	32 ~ 122°F (0 ~ 50°C), Less than 80% RH
Weight	9.9 oz (280g)
Dimensions	Main Unit: 7.9 x 2.7 x 1.2" (200 x 68 x 30mm) Sensor: 3.2 x 2.2 x 0.3" (82 x 55 x 7mm) Sensor Lead: Extends to appx. 3½ ft
Optional Accessories	840057 - RS232 Cable 840094 - RS232 to USB Adaptor Cable 840090 - Water Resistant Instrument Pouch 840092 - Bench-Top Tripod 840093 - Field Tripod 850080 - Software

Unit of Measure	Range	In-Range Display	Res.	Accuracy
Lux	40.00	0 ~ 40.00	0.01	±(3% rdg + 0.5% F.S.)
	400.0	36.6 ~ 400.0	0.1	
	4,000	360 ~ 4,000	1	
	40,000	3,600 ~ 40,000	10	
	400,000	10,000 ~ 400,000	100	<100,000 ± (3% rdg + 0.5% F.S.). >100,000 for reference only
Foot Candle	4.000	0 ~ 3.720	0.001	±(3% rdg + 0.5% F.S.)
	40.00	3.35 ~ 37.20	0.01	
	400.0	33.5 ~ 372.0	0.1	
	4,000	335 ~ 3,720	1	
	40,000	930 ~ 37,200	10	< 9,300 ± (3% rdg + 0.5% F.S.). >9,300 for reference only
Accuracy tested by a standard parallel light, tungsten lamp of 2856°K.				

LIGHT SPECTRUM CHART

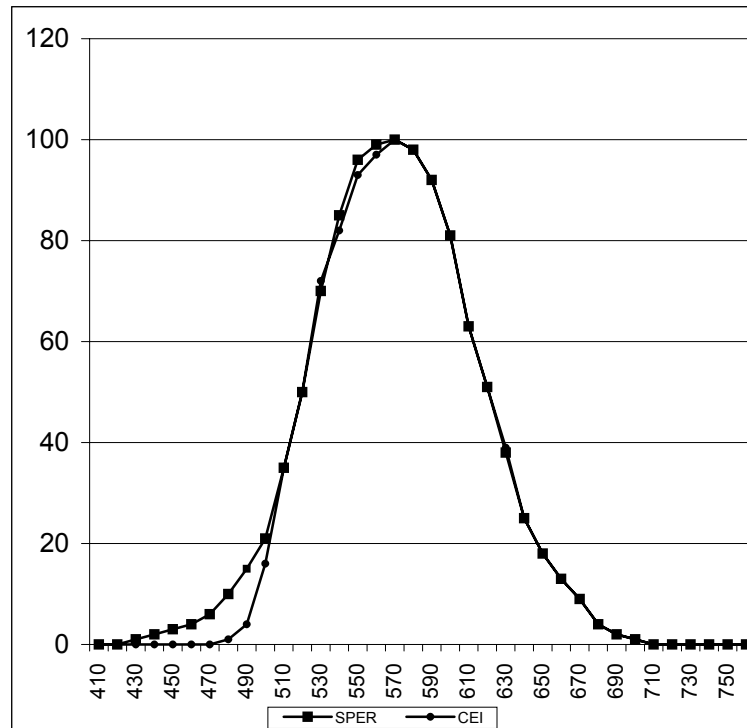

8. WARRANTY

Sper Scientific warrants this product against defects in materials and workmanship for a period of **five (5) years** from the date of purchase, and agrees to repair or replace any defective unit without charge. If your model has since been discontinued, an equivalent Sper Scientific product will be substituted if available. This warranty does not cover probes, batteries, or damage resulting from accident, misuse, or abuse of the product. To obtain warranty service, ship the unit postage prepaid to:

SPER SCIENTIFIC LTD
7720 E Redfield Rd, Suite 7
Scottsdale, AZ 85260
WWW.SPERSCIENTIFIC.COM
INFO@SPERSCIENTIFIC.COM

The defective unit must be accompanied by a description of the problem and your return address. Register your product online or return your warranty card within 10 days of purchase.